

General Description

The 74HC123 are high-speed Si-gate CMOS devices and are pin compatible with Low-power Schottky TTL (LSTTL).

The 74HC123 are dual retriggerable monostable multivibrators with output pulse width control by three methods:

1. The basic pulse is programmed by selection of an external resistor (R_{EXT}) and capacitor (C_{EXT}).
2. Once triggered, the basic output pulse width may be extended by retriggering the gated active LOW-going edge input (\overline{nA}) or the active HIGH-going edge input (nB). By repeating this process, the output pulse period ($nQ=HIGH$, $\overline{nQ}=LOW$) can be made as long as desired. Alternatively an output delay can be terminated at any time by a LOW-going edge on input $n\overline{RD}$, which also inhibits the triggering.
3. An internal connection from $n\overline{RD}$ to the input gates makes it possible to trigger the circuit by a HIGH-going signal at input $n\overline{RD}$.

Features

- DC triggered from active HIGH or active LOW inputs
- Retriggerable for very long pulses up to 100% duty factor
- Direct reset terminates output pulse
- Specified from -40°C to +105°C
- Packaging information: DIP- 16/SOP- 16/TSSOP- 16

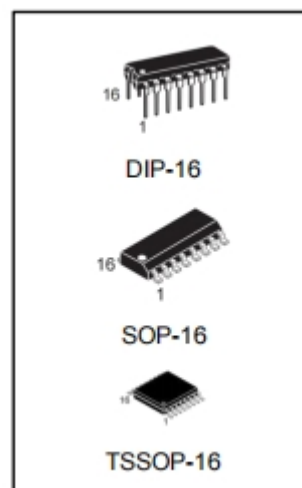

Ordering Information

DEVICE	Package Type	MARKING	Packing	Packing Qty
74HC123N	DIP-16	74HC123	TUBE	1000pcs/box
74HC123M/TR	SOP-16	74HC123	REEL	2500pcs/reel
74HC123MT/TR	TSSOP-16	HC123	REEL	2500pcs/reel

Block Diagram And Pin Description

Block Diagram

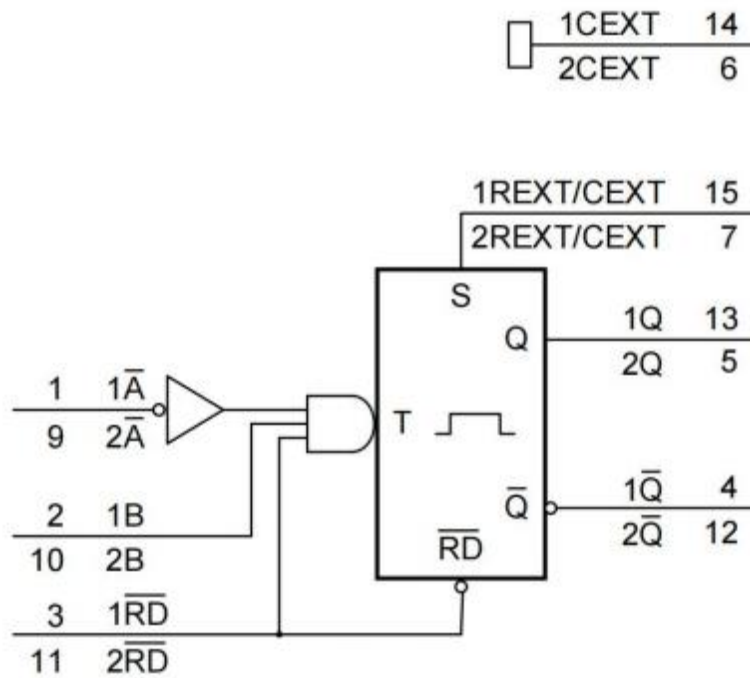

Figure 1. Logic symbol

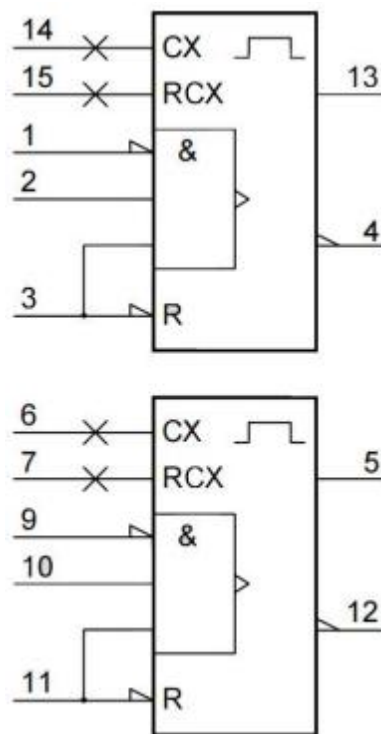

Figure 2. IEC logic symbol

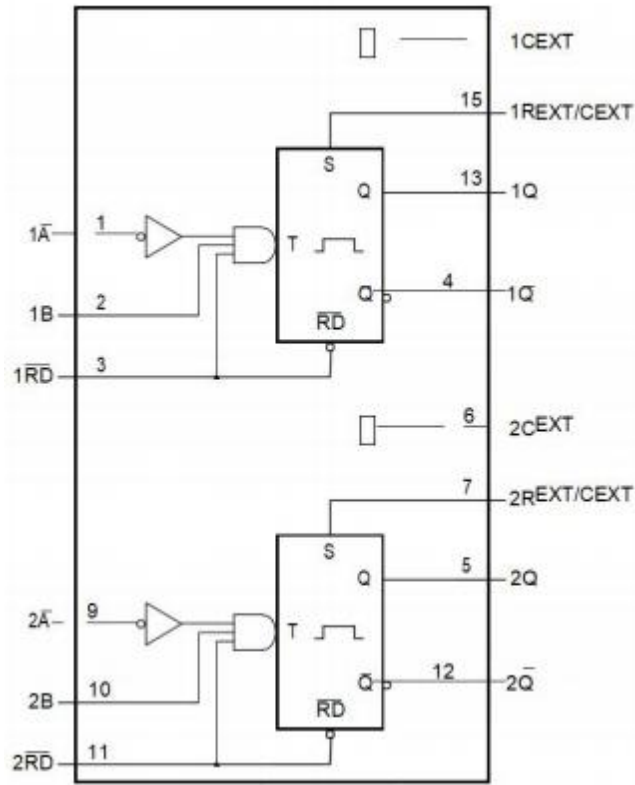

Figure 3. Functional diagram

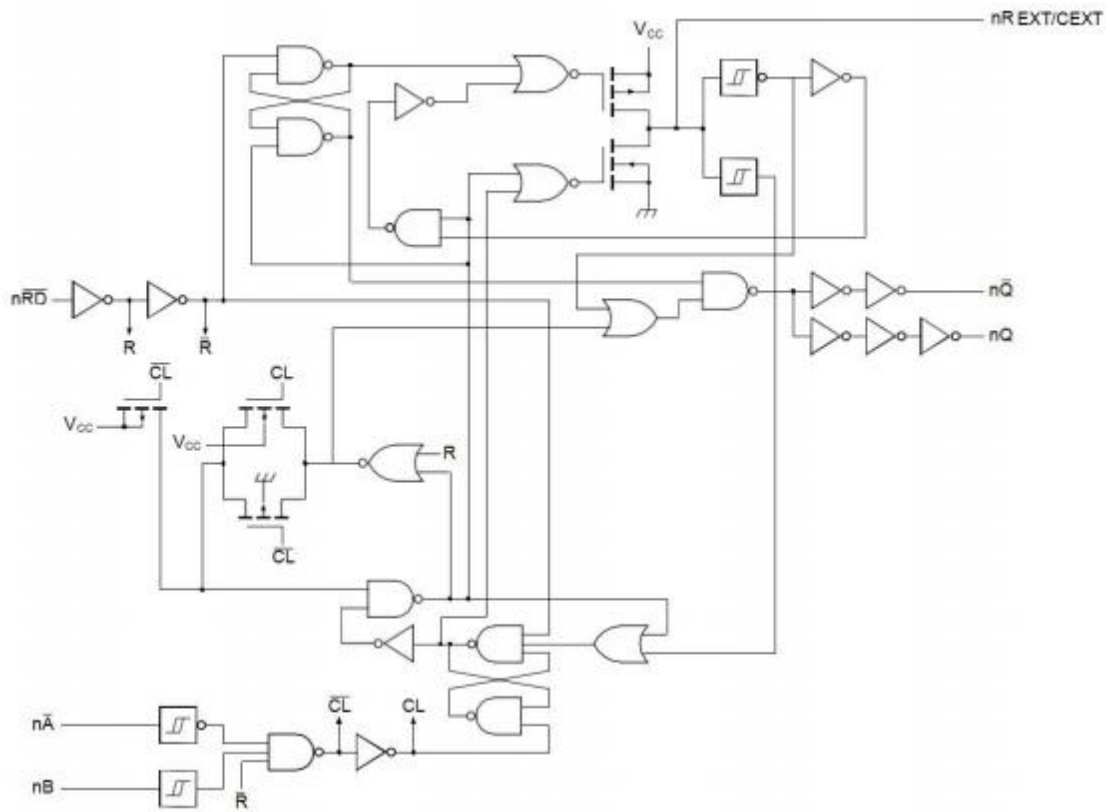
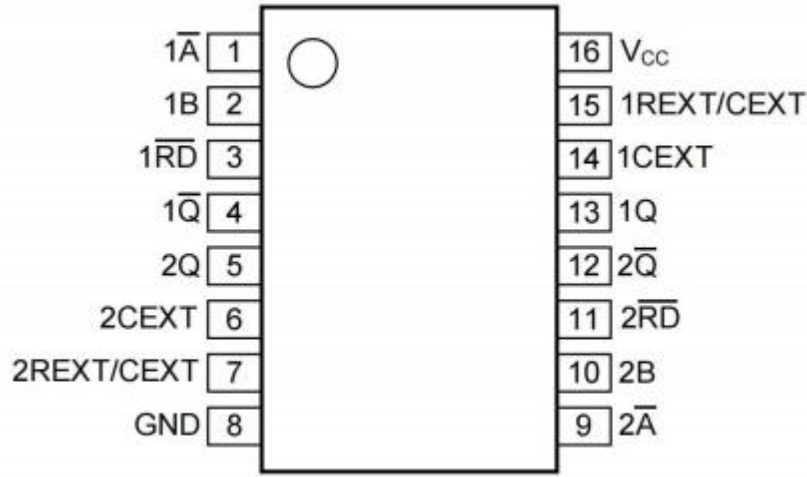

Figure 4. Logic diagram

Pin Configurations









DIP- 16/SOP- 16/TSSOP- 16



Pin Description

Pin No.	Pin Name	Description
1	1A	negative-edge triggered input 1
2	1B	positive-edge triggered input 1
3	1RD	direct reset LOW and positive-edge triggered input 1
4	1Q	active LOW output 1
5	2Q	active HIGH output 2
6	2CEXT	external capacitor connection 2
7	2REXT/CEXT	external resistor and capacitor connection 2
8	GND	ground (0V)
9	2A	negative-edge triggered input 2
10	2B	positive-edge triggered input 2
11	2RD	direct reset LOW and positive-edge triggered input 2
12	2Q	active LOW output 2
13	1Q	active HIGH output 1
14	1CEXT	external capacitor connection 1
15	1REXT/CEXT	external resistor and capacitor connection 1
16	V _{CC}	supply voltage

Function Table

Input			Output	
$n\overline{RD}$	$n\overline{A}$	nB	nQ	$n\overline{Q}$
L	X	X	L	H
X	H	X	L	H
X	X	L	L	H
H	L	↑		
H	↓	H		
↑	L	H		

Note:

1. H=HIGH voltage level; L=LOW voltage level; X=don't care.
2. ↑=LOW-to-HIGH transition; ↓=HIGH-to-LOW transition.
3. =one HIGH level output pulse; =one LOW level output pulse.
4. If the mono stable was triggered before this condition was established, the pulse will continue as programmed.

Electrical Parameter

Absolute Maximum Ratings

(Voltages are referenced to GND (ground=0V), unless otherwise specified.)

Parameter	Symbol	Conditions	Min.	Max.	Unit
supply voltage	V_{CC}	-	-0.5	+7.0	V
input clamping current	I_{IK}	$V_i < -0.5V$ or $V_i > V_{CC}+0.5V$	-	±20	mA
output clamping current	I_{OK}	$V_o < -0.5V$ or $V_o > V_{CC}+0.5V$	-	±20	mA
output current	I_o	except for pins nREXT/CEXT; $V_o = -0.5V$ to $(V_{CC}+0.5V)$	-	±25	mA
supply current	I_{CC}	-	-	50	mA
ground current	I_{GND}	-	-	-50	mA
storage temperature	T_{stg}	-	-65	+150	°C
total power dissipation	P_{tot}	-	-	500	mW
soldering temperature	T_L	10s	DIP	245	°C
			SOP	245	°C

Note: 5、 Absolute Maximum Ratings indicate limits beyond which damage to the device may occur. Operating Ratings indicate conditions for which the device is intended to be functional, but specific performance is not ensured.

6、 For DIP16 packages: above 70°C the value of P_{tot} derates linearly with 12mW/K.

7、 For SOP16 packages: above 70°C the value of P_{tot} derates linearly with 8mW/K.

8、 For (T)SSOP16 packages: above 60°C the value of P_{tot} derates linearly with 5.5mW/K

Recommended Operating Conditions

Parameter	Symbol	Conditions	Min.	Typ.	Max.	Unit	
supply voltage	V_{CC}	-	2.0	5.0	6.0	V	
input voltage	V_I	-	0	-	VCC	V	
output voltage	V_O	-	0	-	VCC	V	
input transition rise and fall rate	$\Delta t/\Delta V$	$n \overline{RD}$ input	$V_{CC}=2.0V$	-	-	625	ns/V
			$V_{CC}=4.5V$	-	1.67	139	ns/V
			$V_{CC}=6.0V$	-	-	83	ns/V
ambient temperature	T_{amb}	-	-40	-	+105	°C	

Electrical Characteristics

DC Characteristics 1 ($T_{amb}=25^{\circ}C$, voltages are referenced to GND (ground=0V), unless otherwise specified.)

Parameter	Symbol	Conditions	Min.	Typ.	Max.	Unit	
HIGH-level input voltage	V_{IH}	$V_{CC}=2.0V$	1.5	1.2	-	V	
		$V_{CC}=4.5V$	3.15	2.4	-	V	
		$V_{CC}=6.0V$	4.2	3.2	-	V	
LOW-level input voltage	V_{IL}	$V_{CC}=2.0V$	-	0.8	0.5	V	
		$V_{CC}=4.5V$	-	2.1	1.35	V	
		$V_{CC}=6.0V$	-	2.8	1.8	V	
HIGH-level output voltage	V_{OH}	$V_I=V_{IH}$ or V_{IL}	$I_O=-20\mu A; V_{CC}=2.0V$	1.9	2.0	-	V
			$I_O=-20\mu A; V_{CC}=4.5V$	4.4	4.5	-	V
			$I_O=-20\mu A; V_{CC}=6.0V$	5.9	6.0	-	V
			$I_O=-4mA; V_{CC}=4.5V$	3.98	4.32	-	V
			$I_O=-5.2mA; V_{CC}=6.0V$	5.48	5.81	-	V
LOW-level output voltage	V_{OL}	$V_I=V_{IH}$ or V_{IL}	$I_O=20\mu A; V_{CC}=2.0V$	-	0	0.1	V
			$I_O=20\mu A; V_{CC}=4.5V$	-	0	0.1	V
			$I_O=20\mu A; V_{CC}=6.0V$	-	0	0.1	V
			$I_O=4mA; V_{CC}=4.5V$	-	0.15	0.26	V
			$I_O=5.2mA; V_{CC}=6.0V$	-	0.16	0.26	V
input leakage current	I_I	$V_I=V_{CC}$ or GND; $V_{CC}=6.0V$	-	-	± 0.1	μA	
supply current	I_{CC}	$V_I=V_{CC}$ or GND; $I_O=0A; V_{CC}=6.0V$	-	-	8.0	μA	
input capacitance	C_I	-	-	3.5	-	pF	

DC Characteristics 2

($T_{amb} = -40^{\circ}\text{C}$ to $+85^{\circ}\text{C}$, voltages are referenced to GND (ground=0V), unless otherwise specified.)

Parameter	Symbol	Conditions	Min.	Typ.	Max.	Unit	
HIGH-level input voltage	V_{IH}	VCC=2.0V	1.5	-	-	V	
		VCC=4.5V	3.15	-	-	V	
		VCC=6.0V	4.2	-	-	V	
LOW-level input voltage	V_{IL}	VCC=2.0V	-	-	0.5	V	
		VCC=4.5V	-	-	1.35	V	
		VCC=6.0V	-	-	1.8	V	
HIGH-level output voltage	V_{OH}	$V_I = V_{IH}$ or V_{IL}	IO=-20uA; VCC=2.0V	1.9	-	-	V
			IO=-20uA; VCC=4.5V	4.4	-	-	V
			IO=-20uA; VCC=6.0V	5.9	-	-	V
			IO=-4mA; VCC=4.5V	3.84	-	-	V
			IO=-5.2mA; VCC=6.0V	5.34	-	-	V
LOW-level output voltage	V_{OL}	$V_I = V_{IH}$ or V_{IL}	IO=20uA; VCC=2.0V	-	-	0.1	V
			IO=20uA; VCC=4.5V	-	-	0.1	V
			IO=20uA; VCC=6.0V	-	-	0.1	V
			IO=4mA; VCC=4.5V	-	-	0.33	V
			IO=5.2mA; VCC=6.0V	-	-	0.33	V
input leakage current	I_i	$V_I = V_{CC}$ or GND; VCC=6.0V	-	-	± 1.0	μA	
supply current	I_{CC}	$V_I = V_{CC}$ or GND; IO=0A; VCC=6.0V	-	-	80	μA	

DC Characteristics 3

(Tamb=-40°C to +105°C, voltages are referenced to GND (ground=0V), unless otherwise specified.)

Parameter	Symbol	Conditions	Min.	Typ.	Max.	Unit	
HIGH-level input voltage	VIH	VCC=2.0V	1.5	-	-	V	
		VCC=4.5V	3.15	-	-	V	
		VCC=6.0V	4.2	-	-	V	
LOW-level input voltage	VIL	VCC=2.0V	-	-	0.5	V	
		VCC=4.5V	-	-	1.35	V	
		VCC=6.0V	-	-	1.8	V	
HIGH-level output voltage	VOH	VI = VIH or VIL	IO=-20uA; VCC=2.0V	1.9	-	-	V
			IO=-20uA; VCC=4.5V	4.4	-	-	V
			IO=-20uA; VCC=6.0V	5.9	-	-	V
			IO=-4mA; VCC=4.5V	3.7	-	-	V
			IO=-5.2mA; VCC=6.0V	5.2	-	-	V
LOW-level output voltage	VOL	VI = VIH or VIL	IO=20uA; VCC=2.0V	-	-	0.1	V
			IO=20uA; VCC=4.5V	-	-	0.1	V
			IO=20uA; VCC=6.0V	-	-	0.1	V
			IO=4mA; VCC=4.5V	-	-	0.4	V
			IO=5.2mA; VCC=6.0V	-	-	0.4	V
input leakage current	II	VI=VCC or GND; VCC=6.0V	-	-	±1.0	uA	
supply current	ICC	VI=VCC or GND; IO=0A; VCC=6.0V	-	-	160	uA	

AC Characteristics 1

($T_{amb}=25^{\circ}\text{C}$, voltages are referenced to GND (ground=0V); $C_L=50\text{pF}$, unless otherwise specified.)

Parameter	Symbol	Conditions	Min.	Typ.	Max.	Unit	
propagation delay	tpd	\overline{nRD} , \overline{nA} , nB to nQ or $n\overline{Q}$; CEXT=0pF; REXT=5k Ω ; see Figure 6[1]	VCC=2.0V	-	83	255	ns
			VCC=4.5V	-	30	51	ns
			VCC=5.0V; CL= 15pF	-	26	-	ns
			VCC=6.0V	-	24	43	ns
		$n\overline{RD}$ (reset) to nQ or $n\overline{Q}$; CEXT=0pF; REXT=5k Ω ; see Figure 6	VCC=2.0V	-	66	215	ns
			VCC=4.5V	-	25	43	ns
			VCC=5.0V; CL= 15pF	-	20	-	ns
			VCC=6.0V	-	19	37	ns
transition time	tt	see Figure 6[1]	VCC=2.0V	-	19	75	ns
			VCC=4.5V	-	7	15	ns
			VCC=6.0V	-	6	13	ns
pulse width	tw	$n\overline{A}$ LOW; see Figure 7	VCC=2.0V	100	8	-	ns
			VCC=4.5V	20	3	-	ns
			VCC=6.0V	17	2	-	ns
		nB HIGH; see Figure 7	VCC=2.0V	100	17	-	ns
			VCC=4.5V	20	6	-	ns
			VCC=6.0V	17	5	-	ns
		$n\overline{RD}$ LOW; see Figure 8	VCC=2.0V	100	14	-	ns
			VCC=4.5V	20	5	-	ns
			VCC=6.0V	17	4	-	ns
		nQ HIGH and $n\overline{Q}$ LOW; VCC=5.0V; see Figure 7, 8[2]	CEXT= 100nF; REXT= 10k Ω	-	450	-	us
CEXT=0pF; REXT=5k Ω	-		75	-	ns		
retrigger time	trtrig	$n\overline{A}$, nB ; CEXT=0pF; REXT=5k Ω ; VCC=5.0V; see Figure 7 ^{[3][4]}	-	110	-	ns	
external timing resistor	REXT	see Figure 7	VCC=2.0V	10	-	1000	k Ω
			VCC=5.0V	2	-	1000	k Ω
external timing capacitor	CEXT	VCC=5.0V; see Figure 9 ^[4]	-	-	-	pF	
power dissipation capacitance	CPD	per monostable; VI=GND to VCC ^[5]	-	54	-	pF	

Note:

- tpd is the same as t_{PLH} and t_{PHL} ; tt is the same as t_{THL} and t_{TLH}
- For other REXT and CEXT combinations see Figure 9. If $C_{EXT}>10\text{nF}$, the next formula is valid.
 $t_w = K \times R_{EXT} \times C_{EXT}$, where;
 t_w =typical output pulse width in ns;
REXT=external resistor in k Ω ; CEXT=external capacitor in pF;

K=constant = 0.45 for VCC=5.0V and 0.55 for VCC=2.0V;

The inherent test jig and pin capacitance at pins 15 and 7 (nREXT/CEXT) is approximately 7pF.

3. The time to retrigger the monostable multivibrator depends on the values of REXT and CEXT. The output pulse width will only be extended when the time between the active-going edges of the trigger input pulses meets the minimum retrigger time. If CEXT>10pF, the next formula (at VCC=5.0V) for the setup time of a retrigger pulse is valid:

$t_{rtrig}=30+0.19 \times R_{EXT} \times C_{EXT}^{0.9}+13 \times R_{EXT}^{1.05}$, where:

t_{rtrig}=retrigger time in ns;

C_{EXT}=external capacitor in pF; R_{EXT}=external resistor in kΩ.

The inherent test jig and pin capacitance at pins 15 and 7 (nREXT/CEXT) is 7pF.

4. When the device is powered-up, initiate the device via a reset pulse, when CEXT<50pF

5. CPD is used to determine the dynamic power dissipation (PD in uW).

$P_D=C_{PD} \times V_{CC}^2 \times f_i + \sum (C_L \times V_{CC}^2 \times f_o) + 0.75 \times C_{EXT} \times V_{CC}^2 \times f_o + D \times 16 \times V_{CC}$ where:

f_i=input frequency in MHz; f_o=output frequency in MHz;

D=duty factor in %; C_L=output load capacitance in pF;

VCC=supply voltage in V;

CEXT=timing capacitance in pF;

∑ (C_L × V_{CC}² × f_o)=sum of outputs.

AC Characteristics 2

(T_{amb}=-40°C to +85°C, GND=0V; C_L=50pF, unless otherwise specified.)

Parameter	Symbol	Conditions	Min.	Typ.	Max.	Unit	
propagation delay	tpd	nRD, nA, nB to nQ or nQ;	V _{CC} =2.0V	-	-	320	ns
		C _{EXT} =0pF;	V _{CC} =4.5V	-	-	64	ns
		R _{EXT} =5kΩ; see Figure 6[1]	V _{CC} =6.0V	-	-	54	ns
		nRD (reset) to nQ	V _{CC} =2.0V	-	-	270	ns
		or nQ;	V _{CC} =4.5V	-	-	54	ns
		C _{EXT} =0pF; R _{EXT} =5kΩ; see Figure 6	V _{CC} =6.0V	-	-	46	ns
transition time	tt	see Figure 6[1]	V _{CC} =2.0V	-	-	95	ns
			V _{CC} =4.5V	-	-	19	ns
			V _{CC} =6.0V	-	-	16	ns
pulse width	tw	nA LOW; see Figure 7	V _{CC} =2.0V	125	-	-	ns
			V _{CC} =4.5V	25	-	-	ns
			V _{CC} =6.0V	21	-	-	ns
		nB HIGH; see Figure 7	V _{CC} =2.0V	125	-	-	ns
			V _{CC} =4.5V	25	-	-	ns
			V _{CC} =6.0V	21	-	-	ns
		nRD LOW; see Figure 8	V _{CC} =2.0V	125	-	-	ns
			V _{CC} =4.5V	25	-	-	ns
			V _{CC} =6.0V	21	-	-	ns

Note:

[1] t_{pd} is the same as t_{PLH} and t_{PHL} ; t_t is the same as t_{THL} and t_{TLH} .

AC Characteristics 3

($T_{amb} = -40^{\circ}\text{C}$ to $+105^{\circ}\text{C}$, $\text{GND} = 0\text{V}$; $C_L = 50\text{pF}$, unless otherwise specified.)

Parameter	Symbol	Conditions	Min.	Typ.	Max.	Unit	
propagation delay	t_{pd}	\overline{nRD} , \overline{nA} , \overline{nB} to \overline{nQ} or \overline{nQ} ; $C_{EXT} = 0\text{pF}$; $R_{EXT} = 5\text{k}\Omega$; see Figure 6[1]	$V_{CC} = 2.0\text{V}$	-	-	385	ns
			$V_{CC} = 4.5\text{V}$	-	-	77	ns
			$V_{CC} = 6.0\text{V}$	-	-	65	ns
		\overline{nRD} (reset) to \overline{nQ} or \overline{nQ} ; $C_{EXT} = 0\text{pF}$; $R_{EXT} = 5\text{k}\Omega$; see Figure 6	$V_{CC} = 2.0\text{V}$	-	-	325	ns
			$V_{CC} = 4.5\text{V}$	-	-	65	ns
			$V_{CC} = 6.0\text{V}$	-	-	55	ns
transition time	t_t	see Figure 6[1]	$V_{CC} = 2.0\text{V}$	-	-	110	ns
			$V_{CC} = 4.5\text{V}$	-	-	22	ns
			$V_{CC} = 6.0\text{V}$	-	-	19	ns
pulse width	t_w	\overline{nA} LOW; see Figure 7	$V_{CC} = 2.0\text{V}$	150	-	-	ns
			$V_{CC} = 4.5\text{V}$	30	-	-	ns
			$V_{CC} = 6.0\text{V}$	26	-	-	ns
		\overline{nB} HIGH;	$V_{CC} = 2.0\text{V}$	150	-	-	ns
		see Figure 7	$V_{CC} = 4.5\text{V}$	30	-	-	ns
			$V_{CC} = 6.0\text{V}$	26	-	-	ns
		\overline{nRD} LOW; see Figure 8	$V_{CC} = 2.0\text{V}$	150	-	-	ns
			$V_{CC} = 4.5\text{V}$	30	-	-	ns
			$V_{CC} = 6.0\text{V}$	26	-	-	ns

Note:

[1] t_{pd} is the same as t_{PLH} and t_{PHL} ; t_t is the same as t_{THL} and t_{TLH} .

Testing Circuit

AC Testing Circuit

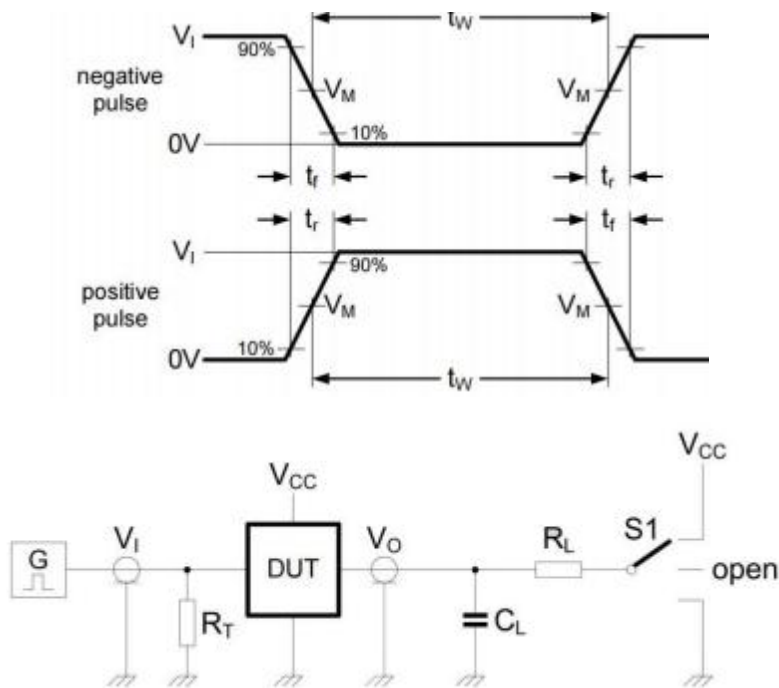

Figure 5. Test circuit for measuring switching times

Definitions for test circuit:

R_L =Load resistance.

C_L =Load capacitance including jig and probe capacitance.

R_T =Termination resistance should be equal to the output impedance Z_o of the pulsegenerator.

S1=Test selection switch.

AC Testing Waveforms

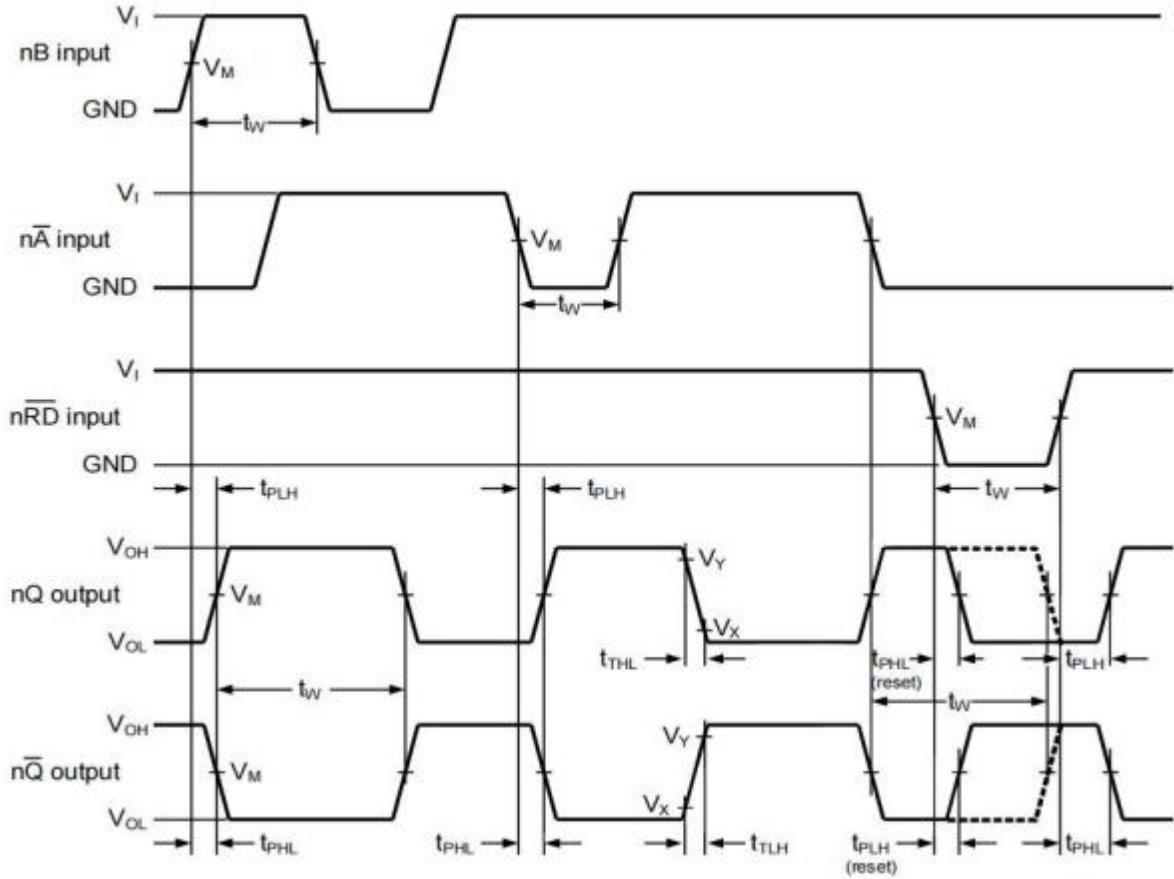

Figure 6. Propagation delays from inputs ($n\bar{A}$, nB , $n\bar{RD}$) to outputs (nQ , $n\bar{Q}$) and output transition times

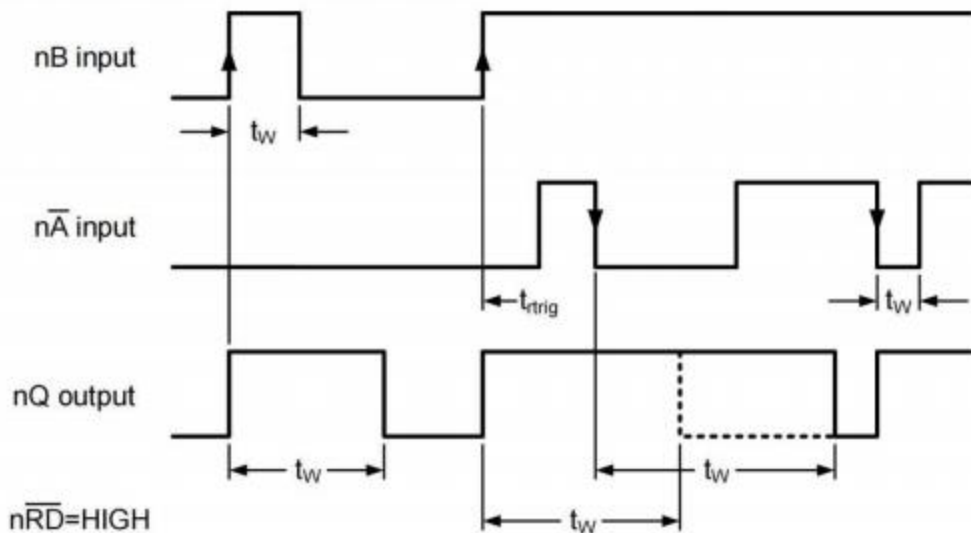

Figure 7. Output pulse control using retrigger pulse

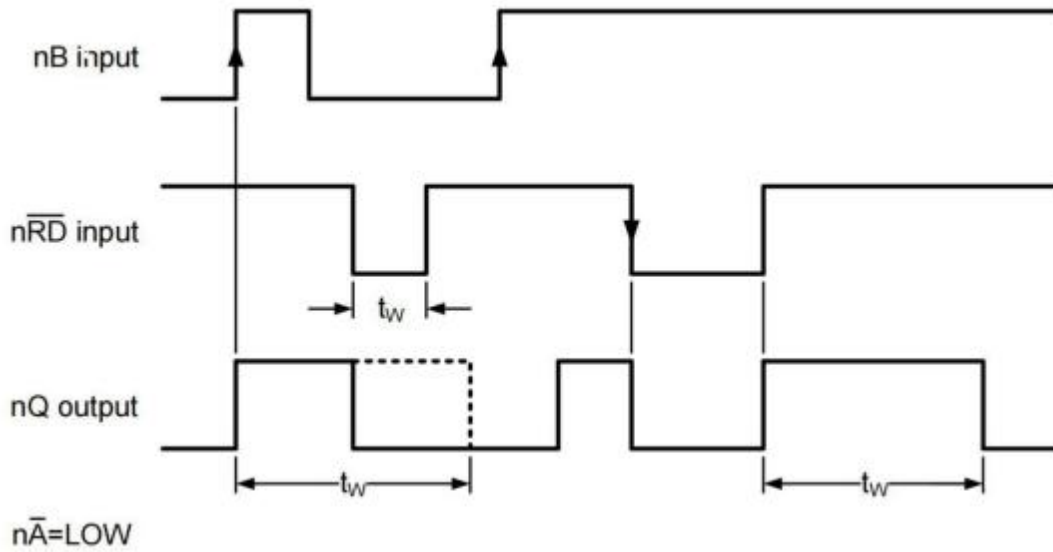
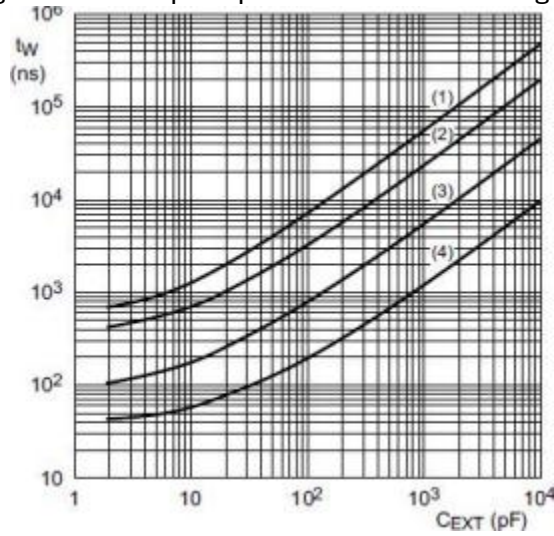

Figure 8. Output pulse control using reset input nRD



$V_{CC}=5.0V$; $T_{amb}=25^{\circ}C$.

$R_{EXT}=100k\Omega$

$R_{EXT}=50k\Omega$

$R_{EXT}=10k\Omega$

$R_{EXT}=2k\Omega$

Figure 9. Typical output pulse width as a function of the external capacitor value

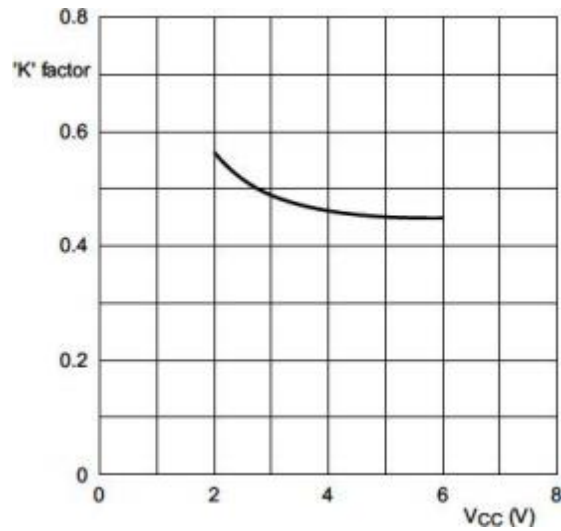

$C_{EXT}=10nF$; $R_{EXT}=10k\Omega$ to $100k\Omega$. $T_{amb}=25^{\circ}C$.

Figure 10. 74HC123 typical 'K' factor as function of V_{CC}

Measurement Points

Type	Input	Output
	VM	VM
74HC123	$0.5 \times V_{CC}$	$0.5 \times V_{CC}$

Test data

Type	Input		Load		S1 position
	V _i	t _R , t _F	C _L	R _L	t _{PHL} , t _{PLH}
74HC123	V _{CC}	6ns	15pF, 50pF	1kΩ	Open

Typical Application Circuit And Application Note

Timing component connections

The basic output pulse width is essentially determined by the values of the external timing components R_{EXT} and C_{EXT} .

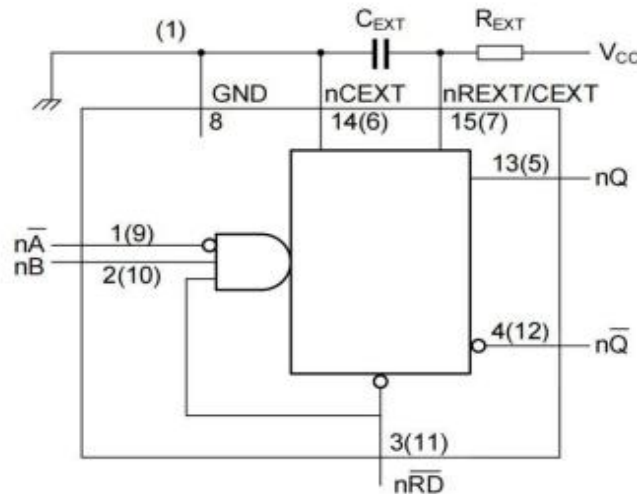

For minimum noise generation it is recommended to ground pins 6 ($2CEXT$) and 14 ($1CEXT$) externally to pin 8 (GND).

Figure 11. Timing component connections

Power-up considerations

When the monostable is powered-up it may produce an output pulse, with a pulse width defined by the values of R_{EXT} and C_{EXT} . This output pulse can be eliminated using the circuit shown in Figure 12.

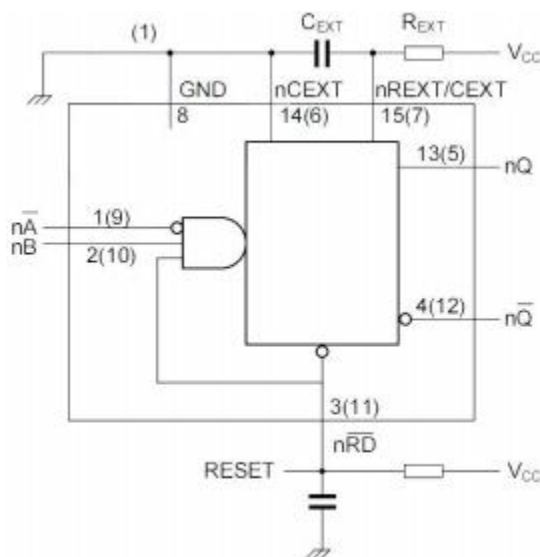

Figure 12. Power-up output pulse elimination circuit

Power-down considerations

A large capacitor C_{EXT} may cause problems when powering-down the monostable due to the energy stored in this capacitor. When a system containing this device is powered-down or a rapid decrease of V_{CC} to zero occurs, the monostable may sustain damage, due to the capacitor discharging through the input protection diodes. To avoid this possibility, use a damping diode (D_{EXT}) preferably a germanium or Schottky type diode able to withstand large current surges and connect as shown in Figure 13.

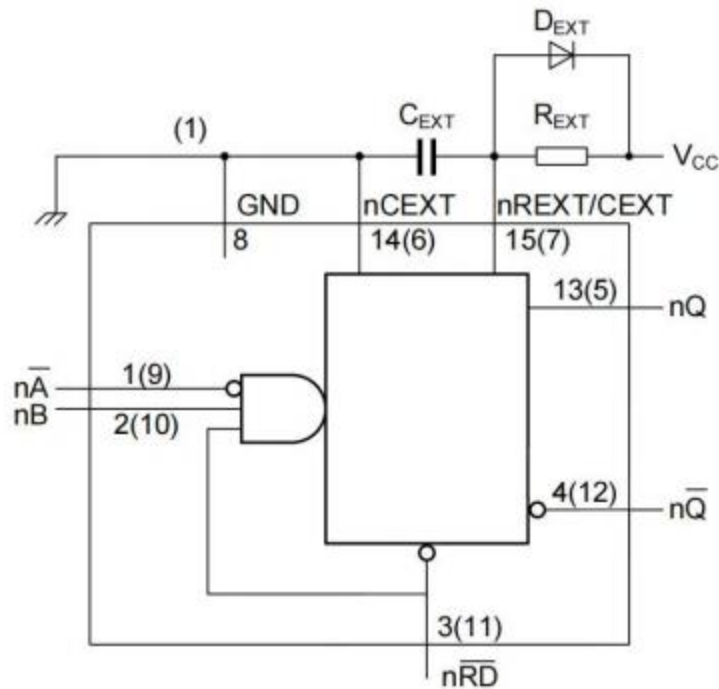
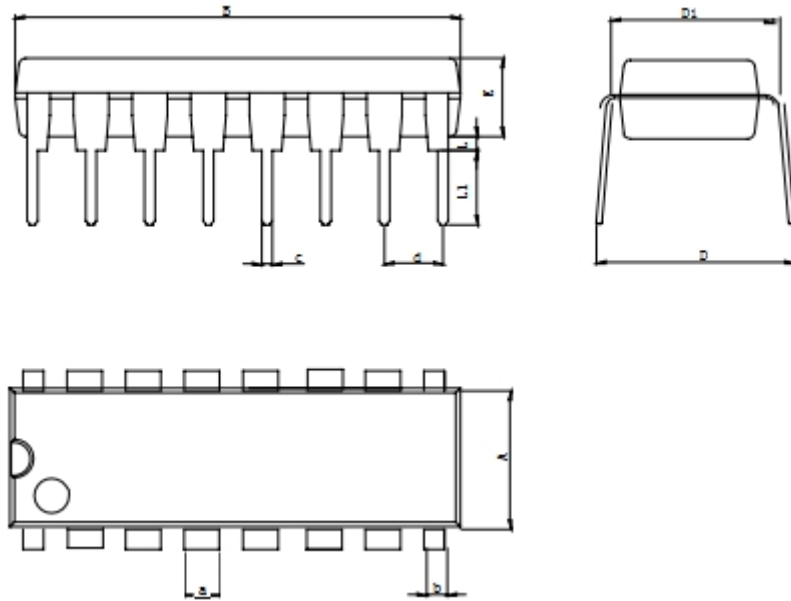

Figure 13. Power-down protection circuit

Physical Dimensions

DIP-16



Dimensions In Millimeters(DIP-16)											
Symbol :	A	B	D	D1	E	L	L1	a	b	c	d
Min :	6.10	18.94	8.10	7.42	3.10	0.50	3.00	1.50	0.85	0.40	2.54 BSC
Max :	6.68	19.56	10.9	7.82	3.55	0.70	3.60	1.55	0.90	0.50	

SOP-16

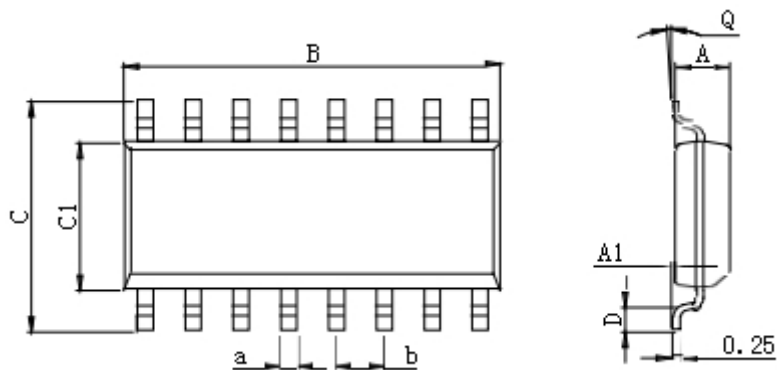

Dimensions In Millimeters(SOP-16)									
Symbol :	A	A1	B	C	C1	D	Q	a	b
Min :	1.35	0.05	9.80	5.80	3.80	0.40	0°	0.35	1.27 BSC
Max :	1.55	0.20	10.0	6.20	4.00	0.80	8°	0.45	

Physical Dimensions

TSSOP-16

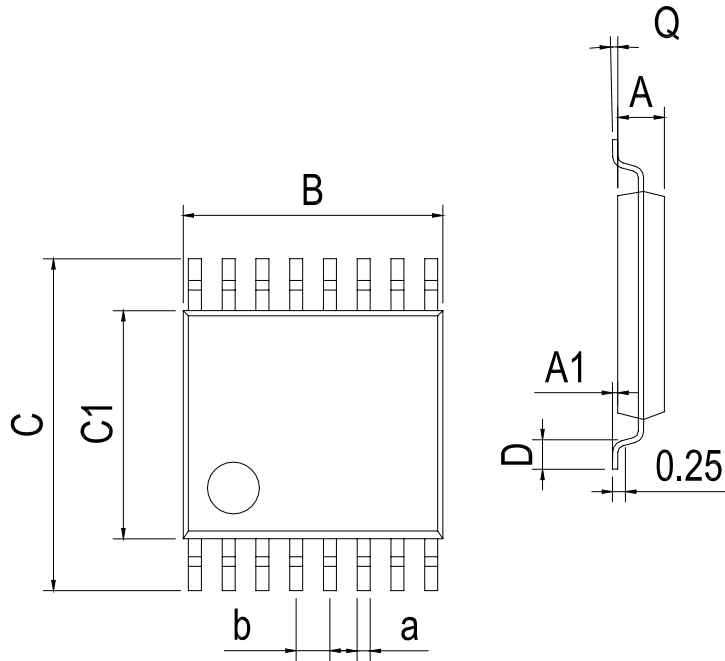

Dimensions In Millimeters(TSSOP-16)									
Symbol :	A	A1	B	C	C1	D	Q	a	b
Min :	0.85	0.05	4.90	6.20	4.30	0.40	0°	0.20	0.65 BSC
Max :	0.95	0.20	5.10	6.60	4.50	0.80	8°	0.25	

