

General Description

The 74HC/HCT240 is an 8-bit inverting buffer/line driver with 3-state outputs. The device can be used as two 4-bit buffers or one 8-bit buffer. The device features two output enables ($1OE$ and $2OE$), each controlling four of the 3-state outputs. A HIGH on nOE causes the outputs to assume a high-impedance OFF-state. Inputs include clamp diodes that enable the use of current limiting resistors to interface inputs to voltages in excess of V_{CC} .

Features

- Input levels:
 - For 74HC240: CMOS level
 - For 74HCT240: TTL level
- Inverting 3-state outputs
- Specified from -40°C to $+105^{\circ}\text{C}$
- Packaging information: DIP20/SOP20/TSSOP20

Order Information

DEVICE	Package Type	MARKING	Packing	Packing QTY
SN74HC240N	DIP-20	74HC240N	Tube	720/Box
SN74HC240DTR	SOP-20	74HC240	Tape	2000/Reel
SN74HCT240DTR	SOP-20	74HCT240	Tape	2000/Reel
SN74HCT240TDTR	TSSOP-20	74HCT240	Tape	2000/Reel

Block Diagram And Pin Description

Block Diagram

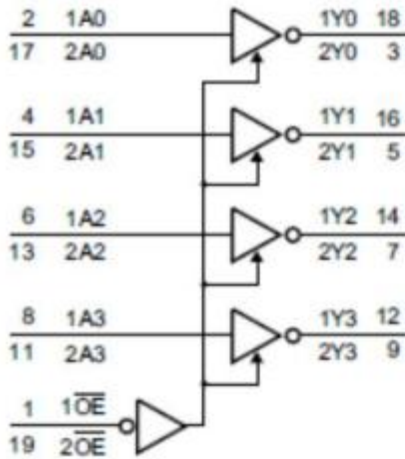

Figure 1. Logic symbol

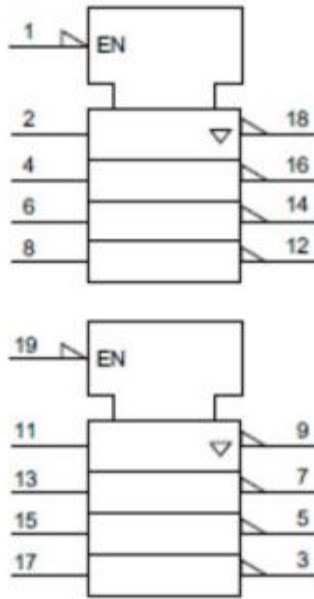

Figure 2. IEC Logic symbol

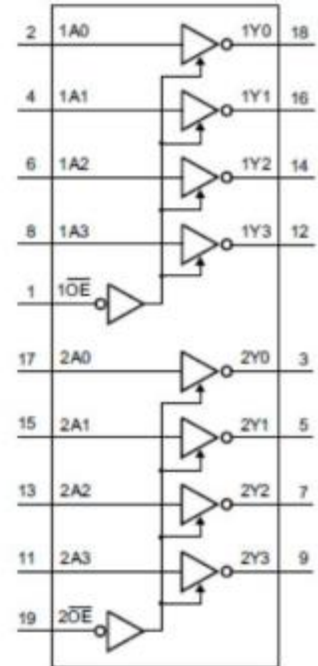
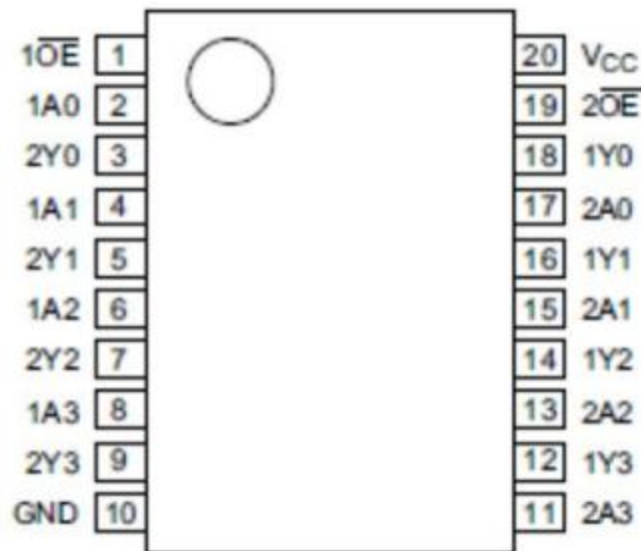

Figure 3. Functional diagram

Pin Configurations



Pin Description

Pin No	Pin Name	Description
1	1OE	output enable input(active LOW)
2	1A0	data input
3	2Y0	bus output
4	1A1	data input
5	2Y1	bus output
6	1A2	data input
7	2Y2	bus output
8	1A3	data input
9	2Y3	bus output
10	GND	ground(0V)
11	2A3	data input
12	1Y3	bus output
13	2A2	data input
14	1Y2	bus output
15	2A1	data input
16	1Y1	bus output
17	2A0	data input
18	1Y0	bus output
19	2OE	output enable input(active LOW)
20	Vcc	supply voltage

Function Table

Input		Output
nOE	nAn	nYn
L	L	H
L	H	L
H	X	Z

Note: H=HIGH voltage level; L=LOW voltage level; X=don't care; Z=high-impedance OFF-state.

Electrical Parameter

Absolute Maximum Ratings (Voltages are referenced to GND (ground=0V), unless otherwise specified.)

Parameter	Symbol	Conditions	Min	Max	Unit
supply voltage	V_{CC}	-	-0.5	+7.0	V
input clamping current	I_{IK}	$V_I < -0.5V$ or $V_I > V_{CC} + 0.5V$	-	± 20	mA
output clamping current	I_{OK}	$V_O < -0.5V$ or $V_O > V_{CC} + 0.5V$	-	± 20	mA
output current	I_O	$-0.5V < V_O < V_{CC} + 0.5V$	-	± 35	mA
supply current	I_{CC}	-	-	70	mA
ground current	I_{GND}	-	-70	-	mA
storage temperature	T_{stg}	-	-65	+150	°C
total power dissipation	P_{tot}	-	-	500	mW
soldering temperature	T_L	10s	DIP	245	°C
			SOP	250	

Note:

- [1] For DIP20 packages: above 70°C the value of P_{tot} derates linearly with 12mW/K.
- [2] For SOP20 packages: above 70°C the value of P_{tot} derates linearly with 8mW/K.
- [3] For (T)SSOP20 packages: above 60°C the value of P_{tot} derates linearly with 5.5mW/K.

Recommended Operating Conditions

Parameter	Symbol	Conditions	Min.	Typ.	Max.	Unit	
74HC240							
supply voltage	V_{CC}	-	2.0	5.0	6.0	V	
input voltage	V_I	-	0	-	V_{CC}	V	
output voltage	V_O	-	0	-	V_{CC}	V	
input transition rise and fall rate	$\Delta t / \Delta V$	-	$V_{CC} = 2.0V$	-	-	625	ns/V
			$V_{CC} = 4.5V$	-	1.67	139	ns/V
			$V_{CC} = 6.0V$	-	-	83	ns/V
ambient temperature	T_{amb}	-	-40	-	+105	°C	
74HCT240							
supply voltage	V_{CC}	-	4.5	5.0	5.5	V	
input voltage	V_I	-	0	-	V_{CC}	V	
output voltage	V_O	-	0	-	V_{CC}	V	
input transition rise and fall rate	$\Delta t / \Delta V$	$V_{CC} = 4.5V$	-	1.67	139	ns/V	
ambient temperature	T_{amb}	-	-40	-	+105	°C	

Electrical Characteristics

DC Characteristics 1 (Tamb=25°C, voltages are referenced to GND (ground=0V), unless otherwise specified.)

Parameter	Symbol	Conditions	Min.	Typ.	Max.	Unit	
74HC240							
HIGH- level input voltage	V _{IH}	V _{CC} =2.0V	1.5	1.2	-	V	
		V _{CC} =4.5V	3.15	2.4	-	V	
		V _{CC} =6.0V	4.2	3.2	-	V	
LOW- level input voltage	V _{IL}	V _{CC} =2.0V	-	0.8	0.5	V	
		V _{CC} =4.5V	-	2.1	1.35	V	
		V _{CC} =6.0V	-	2.8	1.8	V	
HIGH- level output voltage	V _{OH}	V _I =V _{IH} or V _{IL}	I _O =-20uA; V _{CC} =2.0V	1.9	2.0	-	V
			I _O =-20uA; V _{CC} =4.5V	4.4	4.5	-	V
			I _O =-20uA; V _{CC} =6.0V	5.9	6.0	-	V
			I _O =-6.0mA; V _{CC} =4.5V	3.98	4.32	-	V
			I _O =-7.8mA; V _{CC} =6.0V	5.48	5.81	-	V
LOW- level output voltage	V _{OL}	V _I =V _{IH} or V _{IL}	I _O =20uA; V _{CC} =2.0V	-	0	0.1	V
			I _O =20uA; V _{CC} =4.5V	-	0	0.1	V
			I _O =20uA; V _{CC} =6.0V	-	0	0.1	V
			I _O =6.0mA; V _{CC} =4.5V	-	0.15	0.26	V
			I _O =7.8mA; V _{CC} =6.0V	-	0.16	0.26	V
input leakage current	I _I	V _I =V _{CC} or GND; V _{CC} =6.0V	-	-	±0.1	μA	
OFF- state output current	I _{oz}	V _I =V _{IH} or V _{IL} ; V _{CC} =6.0V; V _O =V _{CC} or GND	-	-	±0.5	μA	
supply current	I _{CC}	V _I =V _{CC} or GND; I _O =0A; V _{CC} =6.0V	-	-	8.0	μA	
input apacitance	C _I	-	-	3.5	-	pF	
74HCT240							
HIGH- level input voltage	V _{IH}	V _{CC} =4.5V to 5.5V	2.0	1.6	-	V	
LOW- level input voltage	V _{IL}	V _{CC} =4.5V to 5.5V	-	1.2	0.8	V	
HIGH- level output voltage	V _{OH}	V _I =V _{IH} or V _{IL} V _{CC} =4.5V	I _O =-20uA	4.4	4.5	-	V
			I _O =-6.0uA	3.98	4.32	-	V
LOW- level output voltage	V _{OL}	V _I =V _{IH} or V _{IL} V _{CC} =4.5V	I _O =20uA	-	0	0.1	V
			I _O =6.0uA	-	0.16	0.26	V
input leakage current	I _I	V _I =V _{CC} or GND; V _{CC} =5.5V	-	-	±0.1	μA	
OFF- state output current	I _{oz}	V _I =V _{IH} or V _{IL} ; V _{CC} =5.5V; V _O =V _{CC} or GND	-	-	±0.5	μA	
supply current	I _{CC}	V _I =V _{CC} or GND; I _O =0A; V _{CC} =5.5V	-	-	8.0	μA	
Additional Supply currend	ΔI _{CC}	per input pin; V _I =V _{CC} -2.1V; other inputs at V _{CC} or GND; I _O =0V; V _{CC} =4.5V to 5.5V	nAn or inputs	-	150	540	μA
			nOE input	-	70	252	μA
input apacitance	C _I	-	-	3.5	-	pF	

DC Characteristics 2

(Tamb=-40°C to +85°C, voltages are referenced to GND (ground=0V), unless otherwise specified.)

Parameter	Symbol	Conditions	Min.	Typ.	Max.	Unit	
74HC240							
HIGH- level input voltage	V _{IH}	V _{CC} =2.0V	1.5	-	-	V	
		V _{CC} =4.5V	3.15	-	-	V	
		V _{CC} =6.0V	4.2	-	-	V	
LOW- level input voltage	V _{IL}	V _{CC} =2.0V	-	-	0.5	V	
		V _{CC} =4.5V	-	-	1.35	V	
		V _{CC} =6.0V	-	-	1.8	V	
HIGH- level output voltage	V _{OH}	V _I =V _{IH} or V _{IL}	I _O =-20uA;V _{CC} =2.0V	1.9	-	-	V
			I _O =-20uA;V _{CC} =4.5V	4.4	-	-	V
			I _O =-20uA;V _{CC} =6.0V	5.9	-	-	V
			I _O =-6.0mA;V _{CC} =4.5V	3.84	-	-	V
			I _O =-7.8mA;V _{CC} =6.0V	5.34	-	-	V
LOW- level output voltage	V _{OL}	V _I =V _{IH} or V _{IL}	I _O =20uA;V _{CC} =2.0V	-	-	0.1	V
			I _O =20uA;V _{CC} =4.5V	-	-	0.1	V
			I _O =20uA;V _{CC} =6.0V	-	-	0.1	V
			I _O =6.0mA;V _{CC} =4.5V	-	-	0.33	V
			I _O =7.8mA;V _{CC} =6.0V	-	-	0.33	V
input leakage current	I _I	V _I =V _{CC} or GND;V _{CC} =6.0V	-	-	± 1.0	μA	
OFF- state output current	I _{OZ}	V _I =V _{IH} or V _{IL} ;V _{CC} =6.0V; V _O =V _{CC} or GND	-	-	± 5.0	μA	
supply current	I _{CC}	V _I =V _{CC} or GND;I _O =0A;V _{CC} =6.0V	-	-	80	μA	
74HCT240							
HIGH- level input voltage	V _{IH}	V _{CC} =4.5V to 5.5V	2.0	-	-	V	
LOW- level input voltage	V _{IL}	V _{CC} =4.5V to 5.5V	-	-	0.8	V	
HIGH- level output voltage	V _{OH}	V _I =V _{IH} or V _{IL} V _{CC} =4.5V	I _O =-20uA	4.4	-	-	V
			I _O =-6.0uA	3.84	-	-	V
LOW- level output voltage	V _{OL}	V _I =V _{IH} or V _{IL} V _{CC} =4.5V	I _O =20uA	-	-	0.1	V
			I _O =6.0uA	-	-	0.33	V
input leakage current	I _I	V _I =V _{CC} or GND;V _{CC} =5.5V	-	-	± 1.0	μA	
OFF- state output current	I _{OZ}	V _I =V _{IH} or V _{IL} ;V _{CC} =5.5V; V _O =V _{CC} or GND	-	-	± 5.0	μA	
supply current	I _{CC}	V _I =V _{CC} or GND;I _O =0A;V _{CC} =5.5V	-	-	80	μA	
Additional Supply current	ΔI _{CC}	per input pin; V _I =V _{CC} -2.1V; other inputs at V _{CC} or GND; I _O =0V; V _{CC} =4.5V to 5.5V	nAn or inputs	-	-	675	μA
			nO \bar{E} input	-	-	315	μA

DC Characteristics 3

(Tamb=-40°C to +105°C, voltages are referenced to GND (ground=0V), unless otherwise specified.)

Parameter	Symbol	Conditions	Min.	Typ.	Max.	Unit	
74HC240							
HIGH- level input voltage	V _{IH}	V _{CC} =2.0V	1.5	-	-	V	
		V _{CC} =4.5V	3.15	-	-	V	
		V _{CC} =6.0V	4.2	-	-	V	
LOW- level input voltage	V _{IL}	V _{CC} =2.0V	-	-	0.5	V	
		V _{CC} =4.5V	-	-	1.35	V	
		V _{CC} =6.0V	-	-	1.8	V	
HIGH- level output voltage	V _{OH}	V _I =V _{IH} or V _{IL}	I _O =-20uA;V _{CC} =2.0V	1.9	-	-	V
			I _O =-20uA;V _{CC} =4.5V	4.4	-	-	V
			I _O =-20uA;V _{CC} =6.0V	5.9	-	-	V
			I _O =-6.0mA;V _{CC} =4.5V	3.7	-	-	V
			I _O =-7.8mA;V _{CC} =6.0V	5.2	-	-	V
LOW- level output voltage	V _{OL}	V _I =V _{IH} or V _{IL}	I _O =20uA;V _{CC} =2.0V	-	-	0.1	V
			I _O =20uA;V _{CC} =4.5V	-	-	0.1	V
			I _O =20uA;V _{CC} =6.0V	-	-	0.1	V
			I _O =6.0mA;V _{CC} =4.5V	-	-	0.4	V
			I _O =7.8mA;V _{CC} =6.0V	-	-	0.4	V
input leakage current	I _I	V _I =V _{CC} or GND;V _{CC} =6.0V	-	-	± 1.0	μA	
OFF- state output current	I _{OZ}	V _I =V _{IH} or V _{IL} ;V _{CC} =6.0V; V _O =V _{CC} or GND	-	-	± 10	μA	
supply current	I _{CC}	V _I =V _{CC} or GND;I _O =0A;V _{CC} =6.0V	-	-	160	μA	
74HCT240							
HIGH- level input voltage	V _{IH}	V _{CC} =4.5V to 5.5V	2.0	-	-	V	
LOW- level input voltage	V _{IL}	V _{CC} =4.5V to 5.5V	-	-	0.8	V	
HIGH- level output voltage	V _{OH}	V _I =V _{IH} or V _{IL} V _{CC} =4.5V	I _O =-20uA	4.4	-	-	V
			I _O =-6.0uA	3.7	-	-	V
LOW- level output voltage	V _{OL}	V _I =V _{IH} or V _{IL} V _{CC} =4.5V	I _O =20uA	-	-	0.1	V
			I _O =6.0uA	-	-	0.4	V
input leakage current	I _I	V _I =V _{CC} or GND;V _{CC} =5.5V	-	-	± 1.0	μA	
OFF- state output current	I _{OZ}	V _I =V _{IH} or V _{IL} ;V _{CC} =5.5V; V _O =V _{CC} or GND	-	-	± 10	μA	
supply current	I _{CC}	V _I =V _{CC} or GND;I _O =0A;V _{CC} =5.5V	-	-	16	μA	
Additional Supply current	ΔI _{CC}	per input pin; V _I =V _{CC} -2.1V; other inputs at V _{CC} or GND; I _O =0V; V _{CC} =4.5V to 5.5V	nAn or inputs	-	-	735	μA
			nO \bar{E} input	-	-	343	μA

AC Characteristics 1 (Tamb=25 °C, voltages are referenced to GND(ground=0V), unless otherwise specified.)

Parameter	Symbol	Conditions	Min.	Typ.	Max.	Unit	
74HC240							
nAn to nYn propagation delay	t _{pd}	see Figure5	V _{CC} =2.0V	-	30	100	ns
			V _{CC} =4.5V	-	11	20	ns
			V _{CC} =5.0V;C _L = 15pF	-	9	-	ns
			V _{CC} =6.0V	-	9	17	ns
nO \bar{E} to nYn enable time	t _{en}	see Figure6	V _{CC} =2.0V	-	39	150	ns
			V _{CC} =4.5V	-	14	30	ns
			V _{CC} =6.0V	-	11	26	ns
nO \bar{E} to nYn disable time	t _{dis}	see Figure6	V _{CC} =2.0V	-	41	150	ns
			V _{CC} =4.5V	-	15	30	ns
			V _{CC} =6.0V	-	12	26	ns
transition time	t _t	see Figure5	V _{CC} =2.0V	-	14	60	ns
			V _{CC} =4.5V	-	5	12	ns
			V _{CC} =6.0V	-	4	10	ns
power dissipation capacitance	C _{PD}	per buffer; V _I =GND to V _{CC}	-	30	-	pF	
74HCT240							
nAn to nYn propagation delay	t _{pd}	see Figure5	V _{CC} =4.5V	-	11	20	ns
			V _{CC} =5.0V;C _L = 15pF	-	9	-	ns
nO \bar{E} to nYn enable time	t _{en}	V _{CC} =4.5V;see Figure6	-	13	30	ns	
nO \bar{E} to nYn disable time	t _{dis}	V _{CC} =4.5V;see Figure6	-	13	25	ns	
transition time	t _t	V _{CC} =4.5V;see Figure5	-	5	12	ns	
power dissipation capacitance	C _{PD}	per buffer; V _I =GND to V _{CC} - 1.5V	-	30	-	pF	

Note:

[1]t_{pd} is the same as t_{PLH} and t_{PHL}.

[2]t_t is the same as t_{THL} and t_{TLH}.

[3]C_{PD} is used to determine the dynamic power dissipation (P_D in uW).

$P_D = C_{PD} \times V_{CC}^2 \times f_i \times N + \sum (C_L \times V_{CC}^2 \times f_o)$ where:

f_i=input frequency in MHz;

f_o=output frequency in MHz;

C_L=output load capacitance in pF;

V_{CC}=supply voltage in V;

N=number of inputs switching;

$\sum (C_L \times V_{CC}^2 \times f)$ =sum of outputs.

AC Characteristics 2

(Tamb=40°C to 85°C, voltages are referenced to GND(ground=0V), unless otherwise specified.)

Parameter	Symbol	Conditions	Min.	Typ.	Max.	Unit		
74HC240								
nAn to nYn propagation delay	t _{pd}	see Figure5	V _{CC} =2.0V	-	-	125	ns	
			V _{CC} =4.5V	-	-	25	ns	
			V _{CC} =6.0V	-	-	21	ns	
nOE to nYn enable time	t _{en}	see Figure6	V _{CC} =2.0V	-	-	190	ns	
			V _{CC} =4.5V	-	-	38	ns	
			V _{CC} =6.0V	-	-	33	ns	
nOE to nYn disable time	t _{dis}	see Figure6	V _{CC} =2.0V	-	-	190	ns	
			V _{CC} =4.5V	-	-	38	ns	
			V _{CC} =6.0V	-	-	33	ns	
transition time	t _t	see Figure5	V _{CC} =2.0V	-	-	75	ns	
			V _{CC} =4.5V	-	-	15	ns	
			V _{CC} =6.0V	-	-	13	ns	
74HCT240								
nAn to nYn propagation delay	t _{pd}	see Figure5	V _{CC} =4.5V		-	-	25	ns
nOE to nYn enable time	t _{en}	V _{CC} =4.5V; see Figure6		-	-	38	ns	
nOE to nYn disable time	t _{dis}	V _{CC} =4.5V; see Figure6		-	-	31	ns	
transition time	t _t	V _{CC} =4.5V; see Figure5		-	-	15	ns	

Note:

- [1] t_{pd} is the same as t_{PLH} and t_{PHL}.
- [2] t_{en} is the same as t_{PZL} and t_{PZH}.
- [3] t_{dis} is the same as t_{PLZ} and t_{PHZ}.
- [4] t_t is the same as t_{THL} and t_{TLH}.

AC Characteristics 2

(Tamb=40°C to 105°C, voltages are referenced to GND(ground=0V), unless otherwise specified.)

Parameter	Symbol	Conditions	Min.	Typ.	Max.	Unit	
74HC240							
nAn to nYn propagation delay	t _{pd}	see Figure5	V _{CC} =2.0V	-	-	150	ns
			V _{CC} =4.5V	-	-	30	ns
			V _{CC} =6.0V	-	-	26	ns
nOE to nYn enable time	t _{en}	see Figure6	V _{CC} =2.0V	-	-	225	ns
			V _{CC} =4.5V	-	-	45	ns
			V _{CC} =6.0V	-	-	38	ns
nOE to nYn disable time	t _{dis}	see Figure6	V _{CC} =2.0V	-	-	225	ns
			V _{CC} =4.5V	-	-	45	ns
			V _{CC} =6.0V	-	-	38	ns
transition time	t _t	see Figure5	V _{CC} =2.0V	-	-	90	ns
			V _{CC} =4.5V	-	-	18	ns
			V _{CC} =6.0V	-	-	15	ns

74HCT240							
nAn to nYn propagation delay	t_{pd}	see Figure5	$V_{CC}=4.5V$	-	-	30	ns
nOE to nYn enable time	t_{en}	$V_{CC}=4.5V$; see Figure6		-	-	45	ns
nOE to nYn disable time	t_{dis}	$V_{CC}=4.5V$; see Figure6		-	-	38	ns
transition time	t_t	$V_{CC}=4.5V$; see Figure5		-	-	18	ns

Note:

- [1] t_{pd} is the same as t_{PLH} and t_{PHL} .
- [2] t_{en} is the same as t_{PZL} and t_{PZH} .
- [3] t_{dis} is the same as t_{PLZ} and t_{PHZ} .
- [4] t_t is the same as t_{THL} and t_{TLH} .

Testing Circuit

AC Testing Circuit

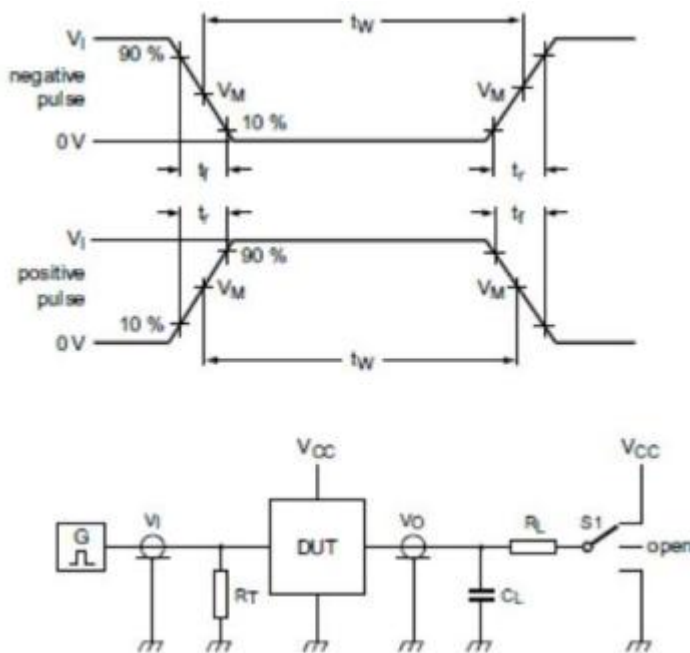

Figure 4. Test circuit for measuring switching times

Definitions for test circuit:

C_L =Load capacitance including jig and probe capacitance.

R_T =Termination resistance should be equal to the output impedance Z_o of the pulse generator.

R_L =Load resistance

S1=Test selection switch

AC Testing Waveforms

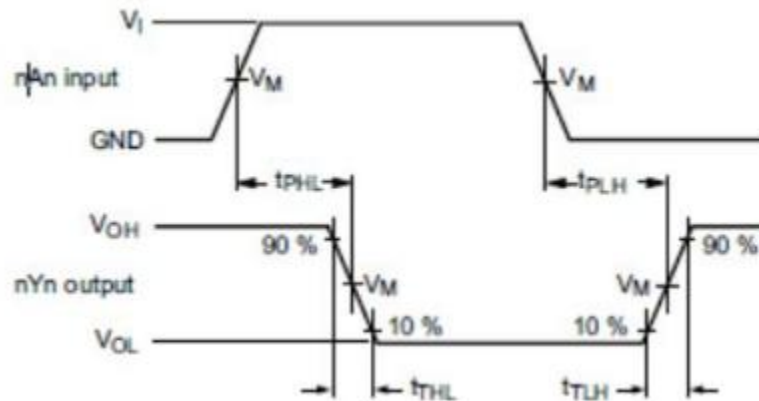

Figure 5. Input (nAn) to output (nYn) propagation delays and output transition times

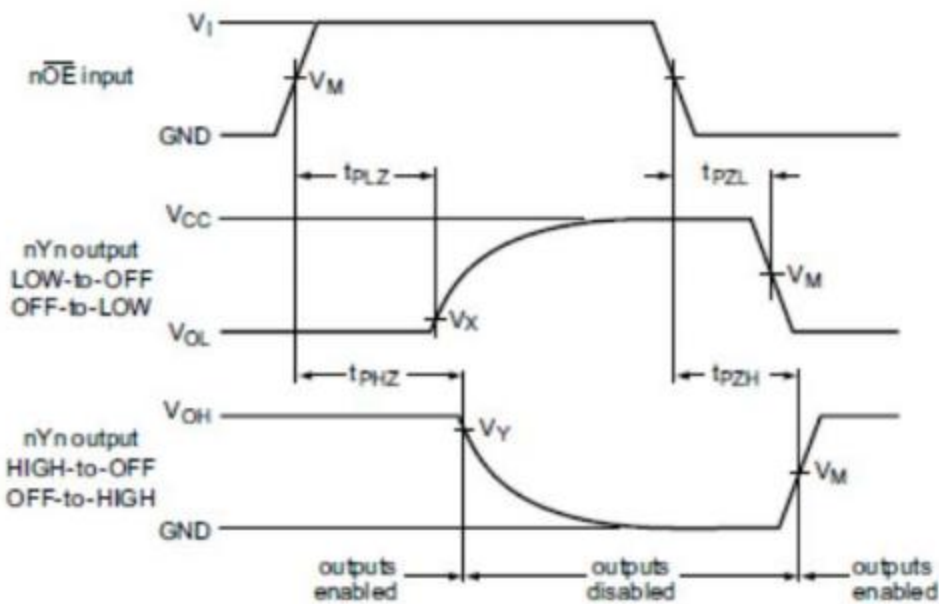

Figure 6. 3-state enable and disable times

Measurement Points

Type	Input		Output				
	V_M		V_M	V_M	V_Y		
74HC240	$0.5 \times V_{CC}$		$0.5 \times V_{CC}$	$0.1 \times V_{CC}$	$0.9 \times V_{CC}$		
74HCT240	1.3V		1.3V	$0.1 \times V_{CC}$	$0.9 \times V_{CC}$		
Type	Input		Load		S1 position		
	V_I	t_r, t_f	C_L	R_L	t_{PHL}, t_{PLH}	t_{PZH}, t_{PHZ}	t_{PZL}, t_{PLZ}
74HC240	V_{CC}	6.0ns	15pF, 50pF	1K Ω	open	GND	V_{CC}
74HCT240	3.0V	6.0ns	15pF, 50pF	1K Ω	open	GND	V_{CC}

Package Information

DIP20

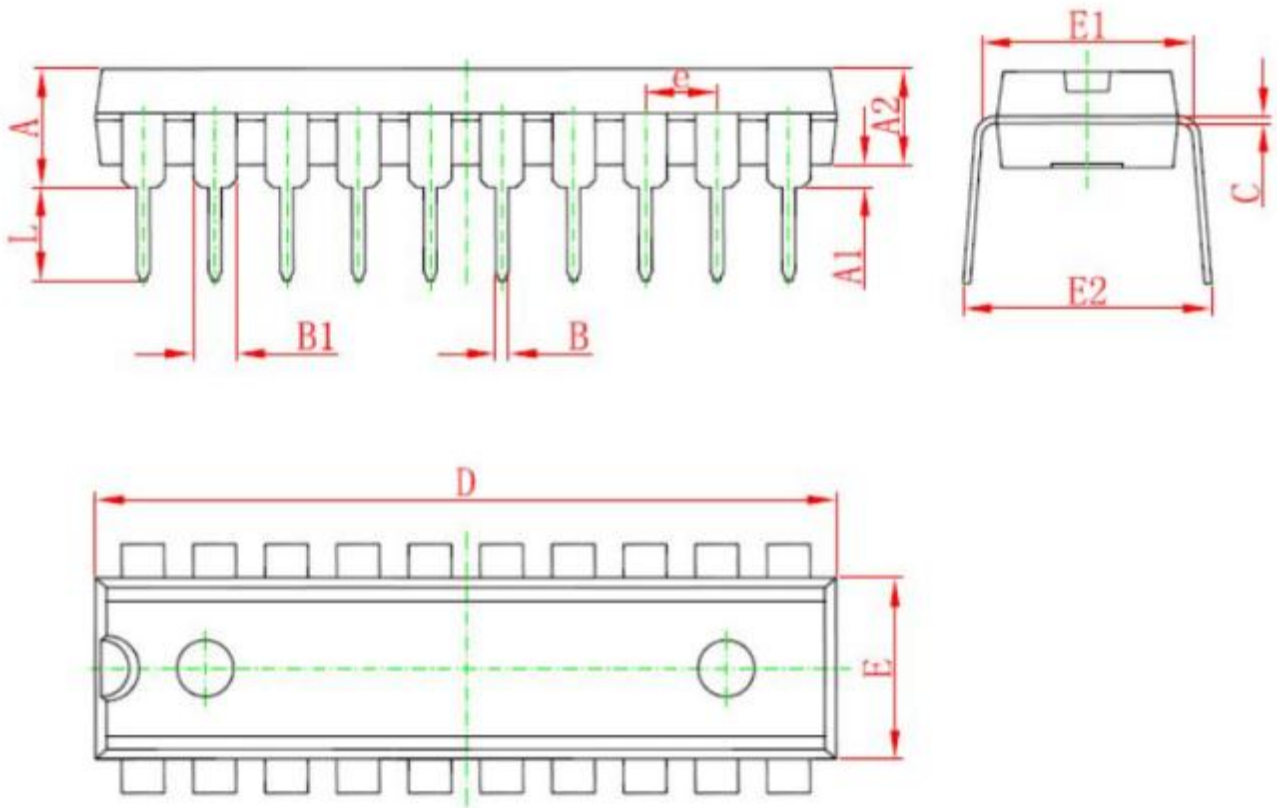

Symbol	Dimensions In Millimeters		Dimensions In Inches	
	Min	Max	Min	Max
A	3.710	4.310	0.146	0.170
A1	0.510		0.020	
A2	3.200	3.600	0.126	0.142
B	0.380	0.570	0.015	0.022
B1	1.524(BSC)		0.060(BSC)	
C	0.204	0.360	0.008	0.014
D	18.800	19.200	0.740	0.756
E	6.200	6.600	0.244	0.260
E1	7.320	7.920	0.288	0.312
e	2.540(BSC)		0.100(BSC)	
L	3.000	3.600	0.118	0.142
E2	8.400	9.000	0.331	0.354

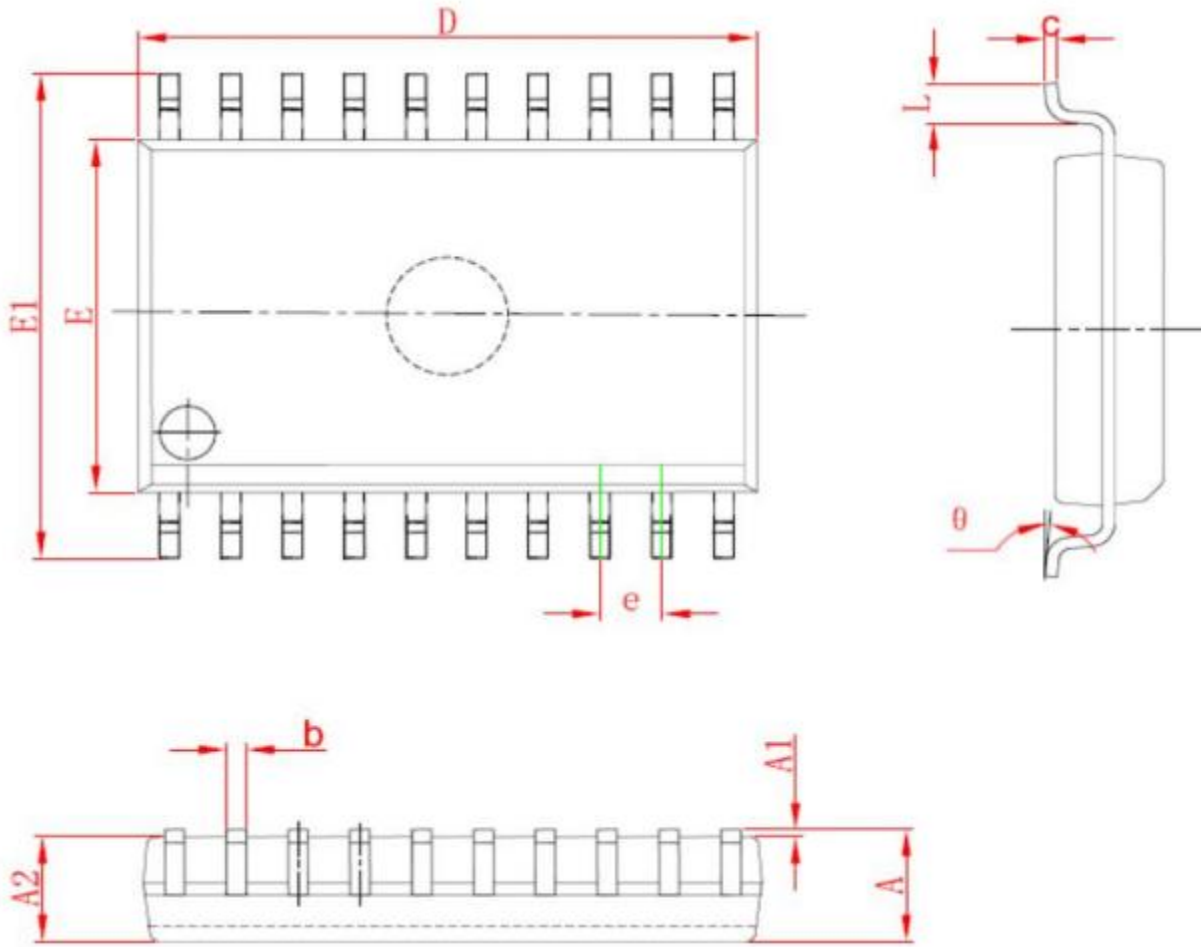

Symbol	Dimensions In Millimeters		Dimensions In Inches	
	Min	Max	Min	Max
A	2.350	2.650	0.093	0.104
A1	0.100	0.300	0.004	0.012
A2	2.100	2.500	0.083	0.098
b	0.330	0.510	0.013	0.020
C	0.204	0.330	0.008	0.013
D	12.520	13.000	0.493	0.512
E	7.400	7.600	0.291	0.299
E1	10.210	10.610	0.402	0.418
e	1.270(BSC)		0.050(BSC)	
L	0.400	1.270	0.016	0.050
θ	0°	8°	0°	8°

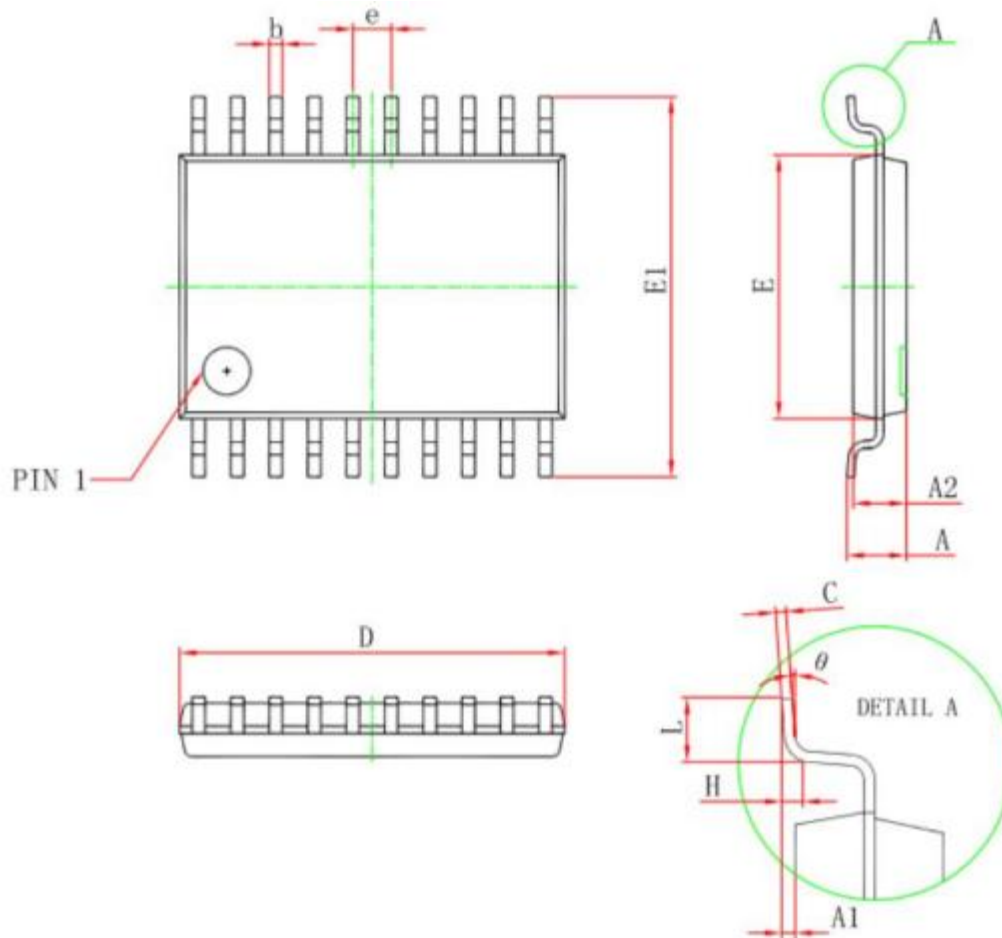

Symbol	Dimensions In Millimeters		Dimensions In Inches	
	Min	Max	Min	Max
D	6.400	6.600	0.252	0.259
E	4.300	4.500	0.169	0.177
b	0.190	0.300	0.007	0.012
c	0.090	0.200	0.004	0.008
E1	6.250	6.550	0.246	0.258
A		1.200		0.047
A2	0.800	1.000	0.031	0.039
A1	0.050	0.150	0.002	0.006
e	0.65(BSC)		0.026(BSC)	
L	0.500	0.700	0.020	0.028
H	0.25(TYP)		0.01(TYP)	
θ	1°	7°	1°	7°

Statements And Notes

Part name	Hazardous substances or Elements									
	Lead and lead compounds	Mercury and mercury compounds	Cadmium and cadmium compounds	Hexavalent chromium compounds	Polybrominated biphenyls	Polybrominated biphenyl ethers	Dibutyl phthalate	Butyl benzyl phthalate	Di-2-ethylhexyl phthalate	Diisobutyl phthalate
Lead frame	○	○	○	○	○	○	○	○	○	○
Plastic resin	○	○	○	○	○	○	○	○	○	○
Chip	○	○	○	○	○	○	○	○	○	○
The lead	○	○	○	○	○	○	○	○	○	○
Plastic sheet installed	○	○	○	○	○	○	○	○	○	○
explanation	○ : Indicates that the content of hazardous substances or elements in the detection limit of the following the SJ/T11363-2006 standard. × : Indicates that the content of hazardous substances or elements exceeding the SJ/T11363-2006 Standard limit requirements									